

# A Review on Development of Wheelchair cum Stretcher

Ranjit P. Katkar<sup>1</sup>, M. V. Nagarhalli<sup>2</sup>, Pankaj S. Desle<sup>3</sup>

PG Student of Department of Mechanical Engineering, RMD Sinhgad School of Engineering, Pune<sup>1</sup>

Head of Department of Mechanical Engineering, RMD Sinhgad School of Engineering, Pune<sup>2</sup>

Assistant Professor of Department of Mechanical Engineering, RMD Sinhgad School of Engineering, Pune<sup>3</sup>

Email: rpkatkar007@gmail.com<sup>1</sup>, pankaj.desle@sinhgad.edu<sup>2</sup>, madhva.nagarhalli.rmdstic@sinhgad.edu<sup>3</sup>

**Abstract-** The number of patients in India is increasing day by day. So in hospitals patients need to be shifted from wheelchair to stretcher, stretcher to beds, bed to wheelchair, or vice versa; which creates unsafe conditions for patients. Also transferring the patients from wheelchair to stretcher, stretcher to beds, bed to wheelchair is always an issue for the attendant or nurse. Sometime during handling, patient and hospital staff suffer from many problem like stresses are produced in the body, some time chances to sleep down the patient. It is required to eliminate all types of possibilities. Understanding the various issues regarding the mobility equipment, the better design will be an asset for the medical field and a helping hand for disabled individuals. There is a need for a wheelchair cum stretcher to facilitate the disabled patient's mobility and to provide novel medical equipment for use in the Indian hospitals. The present research work proposes a development of wheel chair cum stretcher which will follow the standard specification of both wheel chair and stretcher with considering the issues like safety, hygienic, cleaning and functionality.

**Index Terms-** Wheelchair cum stretcher, Wheelchair, Stretcher, Hospital bed.

## 1. INTRODUCTION

In present conditions, the wheelchairs available in market are generally used to transport the patients to and from different wards, e.g. ICU to operation theatre. But what if mobilizing or shifting of patient from wheelchair to stretcher or vice versa causes discomfort. So keeping in mind, this research propose a design of simple & steady wheelchair that can be easily convert to stretcher.

With the help of this wheelchair a patient can be seated on wheelchair on which he can also be operated by converting it to stretcher. That means no movement of patient is required which reduces fatigue and discomfort to him and the nursing staff.

### 1.1 Project Ideation

The patient is confined to bed in hospital and is required to be moved to other places for taking X-ray or undergoing sonography or CT scan procedure. The handling of the patient is rather difficult and is required to be planned meticulously. In patient handling, lots of problems are being faced by the people who handle the patient at home, nursing staffs, and the patient. These problems consist of pain to patient, in various portions of body like shoulder, back, legs, etc.; while moving him from one place to another place. In the hospitals, the nursing staffs are also facing some health problems like pain in their shoulders and backbone, as they have to do the work of patient handling repeatedly.

To overcome the all above problems of patients and hospital staff, there is a need to design a wheelchair

cum stretcher. The plan is to merge both wheelchair & stretcher. So there will no need for shifting patient from his bed or wheelchair to operation table or stretcher as this proposes work will fulfils both the demand.

### 1.2 Problem Definition

Transferring patients in hospitals is a common problem for the caretakers and Patients.

#### 1.2.1. Present Method of Patient handling who meet with an accident

The patient is transfer from various places like from Ambulance to O.T./ ICU/X-ray centres/ MR scan / Sonography can be proceed through various stages.

- Accident spot to stretcher
- Stretcher to ambulance
- Ambulance to hospital stretcher/wheelchair
- Stretcher/ wheelchair to bed at O.P.D
- O.P.D to ICU/ward bed
- O.P.D. to X-Ray centre / MRI / SCAN / Pathology centre
- Back to the bed of ICU/Ward bed

#### 1.2.2 The problem associated with above patient handling

- When the patient is required to transfer on the same floor, he is wrapped in cotton bed sheet and lifted by three to four labours. Due to the handling, stresses are developed in the body of both i.e. patient as well as the nursing staff.

- At the manual handling of the patient various accessories like blood transmission facility, oxygen supply, saline facility, is not available and this may create various problems if the patient is serious.
- When the patient is to be moved from one place to another place, that time if the movement of the patient is on inclined plane and during this movement, there is a chance that the patient may slip or slide down on stretcher.

The above problems which is generated at the timing of patient handling which can be eliminated by developing a new Wheelchair cum Stretcher to handle the patients.

## 2. LITERATURE REVIEW

### 2.1 Wheel Chair

Wheelchairs have been around for hundreds of years, but early wheelchairs were intended only to help a disabled individual move from point A to point B. As society progressed and disabled individuals became more integrated, the role of the wheelchair began to change as well. Wheelchairs are now considered not only a means of transportation but also as a way to allow users to express their individuality.



Fig 1 : Different wheelchair

The earliest records of wheeled furniture was an inscription found on a stone slate in China and a child's bed depicted in a frieze on a Greek vase, both dating back to the 6th century. The first records of wheeled seats being used for transporting the disabled date to three centuries later in China; the Chinese used their invented wheelbarrow to move people as well as heavy objects. A distinction between the two functions was not made for another several hundred years until when images of wheeled chairs made specifically to carry people begin to occur in Chinese art. There were many attempts to connect furniture to wheels dating back to the time of Christ. But perhaps the first wheelchair was invented for King Phillip II of Spain. In 1665 one of the first self-propelled vehicles was invented by Stephan Farfler.

Harry Jennings and his disabled friend Herbert Everest, both mechanical engineers, invented the first lightweight, steel, collapsible wheelchair in 1933. Mr. Everest had broken his back in a mining accident. The two saw the business potential of the invention and went on to become the first mass-manufacturers of wheelchairs: *Everest and Jennings*. Their "x-brace" design is still in common use, albeit with updated materials and other improvements.

In the 1950's the first powered wheelchair was developed. It used a motor to power the wheelchair. It was around the same time that wheelchair sports were first started. In the year 1964 the first Paralympics games were held in Tokyo, Japan. Modern day wheel chairs contain light materials, microprocessor controlled and many more sophisticated systems. There is a revolution of wheelchairs available today driven by needs and desire or man today. The future expects a better range of wheelchairs that could suit the imagination of the human mind and serve the needy.

The basic structure of the wheelchair contains various parts. In simple words its nothing but a set of wheels attached to a chair. There are some important things a wheelchair must contain. A seat must be comfortable,

so that the person does not get tired sitting on it for a long time. It must contain a backrest that provides a good lumbar support. It must have an arm rest at an optimum height and also a foot rest. The most important thing is it must have brakes for the wheels.

## 2.2 Stretcher

A stretcher is a medical device to carry patients for a short duration of time. A stretcher contains a surface which supports for carrying patients, and has handles on either side along its length to help carry it.



Fig 2 : Stretcher

Stretchers have been used since antiquity, on battlefields and in emergency situations, where wheeled vehicles are hindered by rough terrain. In their simplest form, they generally consisted of a canvas sling with long edges sewn to themselves to form pockets through which with wooden poles could be slid. Today there are a wide variety of stretchers available, involving light weight materials, attachments so that it can be fitted to other contraptions.

Meng-Hui Hsu, Hsueh-Yu Chen, Jen-Yu Liu and Chien-Liang Chen (2009) in their paper "Dual-purpose wheelchair mechanism designs" has stated that a wheelchair with dual-function of sitting and lying is usable to the users no matter what he sits or lies. In addition, if the rear wheels of the dual-purpose wheelchair are designed as movable ones, the whole mass-center of the wheelchair can move between the rear and front wheels of the chair.

Sreerag C S, Gopinath C, Manas Ranjan Mishra (2011) in their paper "Design and development of conceptual wheelchair cum stretcher" has stated that mobility aids are useful for patients for transportation and a replacement for walking especially in indoor and outdoor environment. Their study shows that it is possible to save 50% space by the wheelchair-cum-stretcher design. The product will thus likely be an efficient mobility aid in hospitals.

They generated some concepts compared and studied using Pugh method with the bench marked product. And finally one concept was selected as the final concept and it was verified with user opinion.

U. D. Gulhane, R. J. Dahake, O.M.Sharma (2005) In their paper titled "Wheel Chair cum Stretcher, a innovative product for small hospitals and patients", the authors have designed and fabricated a new modified wheelchair cum stretcher. The developed wheelchair can very easily be converted into stretcher as well as operation table depending on the need. Simple parallelogram mechanism has been synthesized for lifting. The mechanism is driven hydraulically. The hydraulic piston can be operated manually as well as automatically. The chair gets converted into stretcher while lifting automatically. Inverted slider crank mechanism is applied for the purpose. Five legged support provides required stability to stretcher. The developed model is economical as compared to the available modern automatic wheelchairs.

Hsin-yi Liu, Rory A. Cooper, Jonathan Pearlman, Rosemarie Cooper, Samuel Connor (2008) In their paper titled "Evaluation of titanium ultra light manual wheelchairs using ANSI/RESNA standards" stated that Comfortable propulsion and support, light weight, and small dimensions are important features that help preserve upper-limb integrity of manual wheelchair users and improve accessibility. The titanium wheelchair is a product developed in response to these goals, but none of the test results of titanium wheelchairs had been disclosed before this study was performed. They hypothesized that these titanium wheelchairs would be in compliance with American National Standards Institute (ANSI)/Rehabilitation Engineering and Assistive Technology Society of North America (RESNA) standards. They tested 12 ultralight titanium rigid-frame wheelchairs (4 models) using ANSI/RESNA testing procedures and compared the test results with previously tested ultralight and lightweight aluminium wheelchairs.

The literature review indicates that the patient handling method and equipment, wheelchair and stretcher is used presently cannot prevent the manual handling of patient from hospital bed to wheelchair/stretcher and vice-versa. Though above authors developed different systems were proposed to transfer the patient from hospital bed to stretcher or vice versa. The proposed system is very complicated and costly and hence not suitable for use in hospital environments present in our country.

## 3. ERGONOMIC DETAILS AND BIS STANDARDS

### 3.1 Ergonomic Details

We know that Ergonomics (or human factors) is the scientific discipline concerned with the understanding of interactions among humans and other elements of a system, and the profession that applies theory, principles, data and methods to design in order to optimize human well-being and overall system

performance. As our study is focused on handling of elderly people & patients in hospitals during shifting from one mobility aid (wheelchair, stretcher) to another, we considered Ergonomics involved & Indian Public Health Standards for design of proposed concept.

As per Indian Public Standards every Hospital should have Barrier free access environment for easy access to non-ambulant (Wheelchair, stretcher), semi ambulant visually disabled & elderly persons as per Govt. of India guidelines.

Below fig. shows Anthropometric data of wheelchair user related to uses within easy reach.

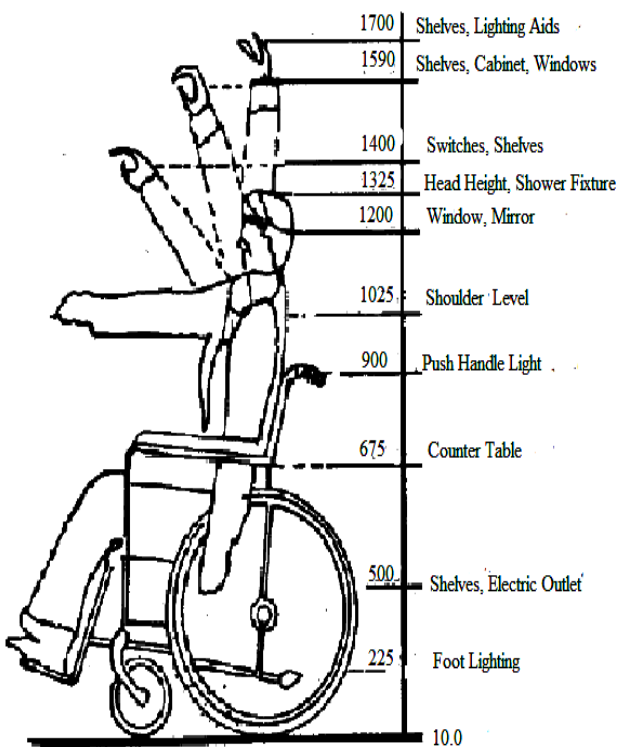

Fig 3 : typical dimension for essential uses with easy reach

3.2 BIS standard for wheelchair

Sr.No.	Specification	Dimension (mm)
1	Overall length	1000-1100
2	Overall width open	650-720
3	Overall height	910-950
4	Seat height from floor	480-510
5	Slope of Seat	1°-3°
6	Slope of backrest with respect to floor	5°-7°
7	Distance between seat and footrest	400-450
8	Armrest height from seat	220-230
9	Seat dept	420-440
10	Clearance of footrest from floor	90-200
11	Clearance of frame from	100±10

	floor	
12	Wheel diameter	609.6*38.1
13	Weight of the wheel chair	25 kg Max

4. CONCLUSION AND FURTHER SUGGESTED WORK

4.1 Scope

- Increases the comfort level of patient and patient handling staff.
- Prevents damages to patient while transferring from wheelchair to stretcher.
- Occupy less space.
- Easily converts from wheelchair to stretcher & vice versa.
- Emergency & serious patients who should not be moved or disturbed from their position can be shifted.
- Shifting of patient is reduced i.e. stretcher is not needed anymore.
- Position of patients can be easily adjusted as per doctors use.
- No special training is required to operate it.

4.2 Limitation

- Increases system weight slightly.
- Increases system cost slightly

4.3 Conclusion

As per the above discussion we concluded that now day in hospitals fully atomized beds, wheelchairs and stretchers are use for the patient handling purpose. But they are very costly and can't be affordable to all the hospital. The stresses developed during the handling of patient in both, i.e., patient and staffs are same for all the hospital. Our aim to provide a better solution for patient handling to these hospitals whose having limitations for the use fully automated beds and wheelchair/stretcher. As per the above problem we propose a new design of wheelchair cum stretcher for patient handling. Cost of such type of wheelchair cum stretcher will affordable for all type of hospitals and it will be beneficial for patient handling .

4.4 Future Work

- Design and development of wheelchair cum stretcher.

REFERENCES

[1] Arvind T Wadgure, R D Ashkedkar , and V N Mujbaile (2013) "Design and development of modified mattresses for patient handling" IJMERR Vol. 2, No. 4, October 2013

[2] Praful R Randive and A V Karmankar (2013) "Stress analysis of mechanisms for trolley-cum-wheelchair" IJMERR Vol. 2, No. 4, October 2013

[3] Meng-Hui Hsu, Hsueh-Yu Chen, Jen-Yu Liu and Chien-Liang Chen (2009) "Dual-purpose

- wheelchair mechanism designs” Proceedings of the International MultiConference of Engineers and Computer Scientists 2009 Vol II ,IMECS 2009, March 18 - 20, 2009, Hong Kong
- [4] Sreerag C S, Gopinath C, Manas Ranjan Mishra “Design and development of conceptual wheelchair cum stretcher” SASTECH , Volume 10, Issue 2, Sep 2011
- [5] U. D. Gulhane, R. J. Dahake, O.M.Sharma “Wheel Chair cum Stretcher, n innovative product for small hospitals and patients” nacomm 2005
- [6] Hsin-yi Liu, Rory A. Cooper, Jonathan Pearlman, Rosemarie Cooper, Samuel Connor (2008) “Evaluation of titanium ultra light manual wheelchairs using ANSI/RESNA standards” Journal of Rehabilitation Research & Development, Volume 45, Number 9, 2008
- [7] John Roberts , “Design and development of a wheelchair enablement device”
- [8] Thomas Jin-Chee Liu, Jin-Wei Liang, Wei-Long Chen, Teng-Hui Chen, “Finite element analysis of composite frames in wheelchair under upward loading” International Journal of Mechanical, Aerospace, Industrial and Mechatronics Engineering Vol:8 No:1, 2014
- [9] Bureau of Indian Standard (BIS), Rehabilitation Equipment-Wheelchairs, Folding size-Specification (First Revision) IS 7554-1991.
- [10] Bureau of Indian Standard (BIS), Specification for stretcher and stretcher carrier, IS 4037 – 1967.
- [11] Anonymous, “History of the wheelchair”, [www.inventors.about.com](http://www.inventors.about.com), retrieved on 27th Sept. 2010.
- [12] Dr. Rory A. Cooper., “Wheelchair selection and configuration”, ISBN 1-888799 – 18 – 8, March 1998.
- [13] Mr. Amos Winter, “Mechanical principle of wheelchair design”, Graduate Student, Department of Mechanical Engineering, Massachusetts Institute of Technology, US, retrieved on 24th Sept. 2010.